

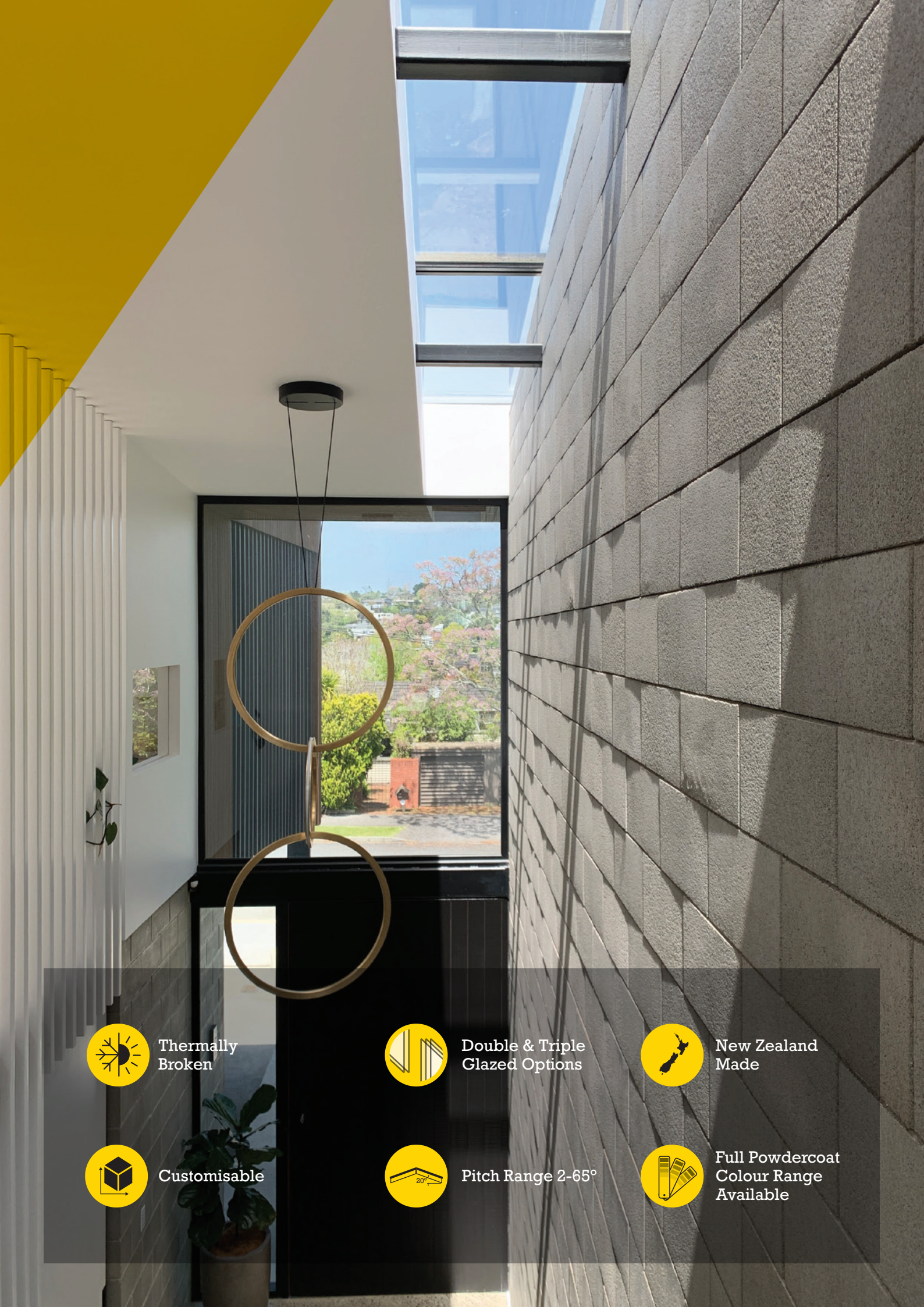

Harmony Array

The Next Generation in Overhead Glazing





Thermally Broken



Double & Triple Glazed Options



New Zealand Made



Customisable



Pitch Range 2-65°



Full Powdercoat Colour Range Available

Harmony Array

Elevating Overhead Glazing Performance with Exceptional Thermal Efficiency

Harmony Array is a next-generation modular rooflight system from Adlux, designed and developed in New Zealand to meet the growing demand for large-scale, thermally broken roof glazing. With a fully welded frame and a continuous thermal break throughout, it delivers exceptional thermal performance without compromising clean lines, design flexibility, or architectural intent. Factory-glazed and custom-manufactured in modular units, Harmony Array allows for efficient on-site installation and can be configured to virtually any length, forming a flush, continuous rooflight tailored to your project needs. Built for performance and aesthetics, it's the ideal roof glazing solution for creating high-performing building envelopes across all climate zones—bringing in more natural light while maintaining energy efficiency, weather protection, and a contemporary style.

Features

- › Thermally Broken Perimeter Frame – Uf0.84
- › Thermally Broken Array with Link Beam – Uf2.67
- › Double & Triple Glazing Options
- › Fully Welded Corners
- › Flush Glazing
- › No limit to the length achievable
- › Self supported spans up to 3.0M
- › Larger spans with structural support
- › Suitable for all climate zones

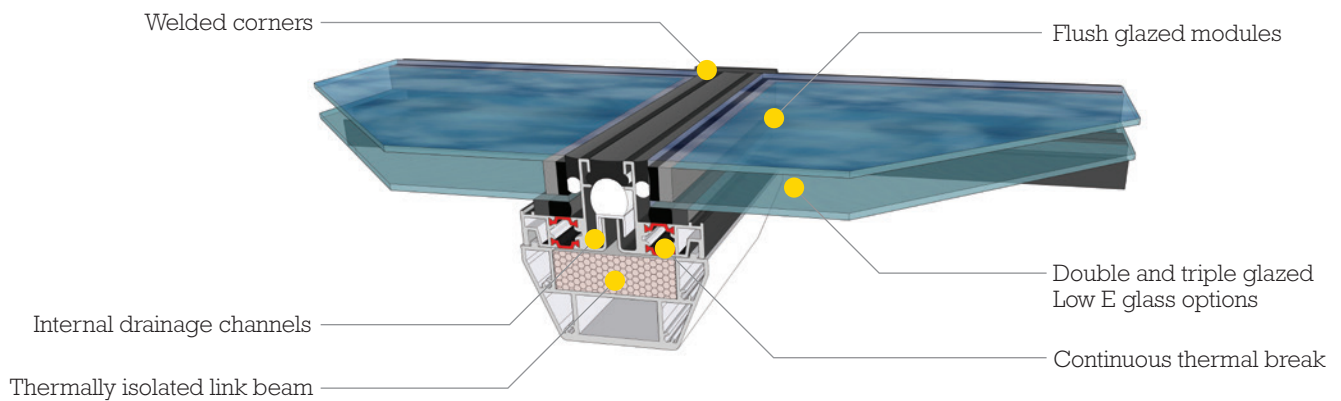

Field of Application

- Flat Roof
- Ridge Lines
- Pitched Roof

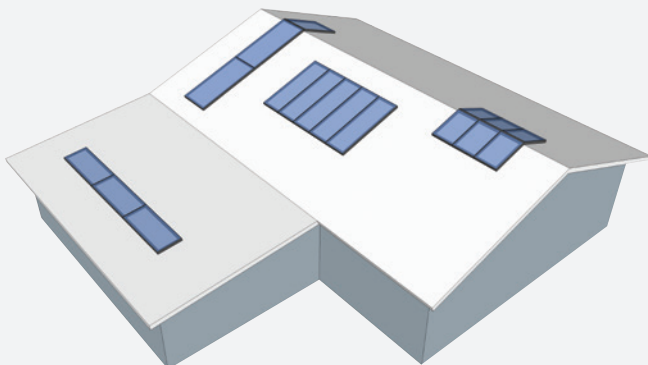

Designed for Thermal Performance

Harmony Array's thermal efficiency is ensured by isolating external and internal profiles with thermal breaks, eliminating cold bridging. Frame performance (Uf) is validated using the latest software to ISO 10077-2 standards.

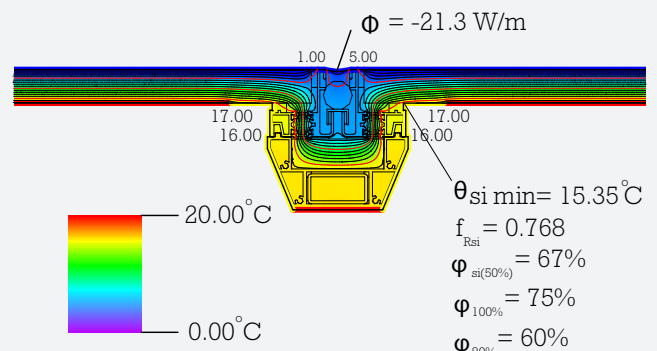



At Adlux, we believe there's life to be found in every home. Our joy is in bringing yours to light.

As a family business with a friendly and capable team, we specialise in the design, supply, and installation of a range of window, lighting, outdoor, and roofing solutions for residential and commercial projects.

With a bespoke approach, we'll work with you to find the best solution for your project.

Whether locally produced or sourced internationally, we'll help you access and choose from a range of world-class, contemporary products that combine style with seamless function.

All of our products are rigorously tested for quality and New Zealand living conditions.

They are designed to enhance your environment for years to come.

Adlux Industries Limited

30 Sistema Way, Mangere
Auckland 2022
New Zealand

P.O. Box 13-866, Auckland 1643
New Zealand

0800 500 557

sales@adlux.co.nz
www.adlux.co.nz

let life in 

22/05/2025

